

CAD FILE :

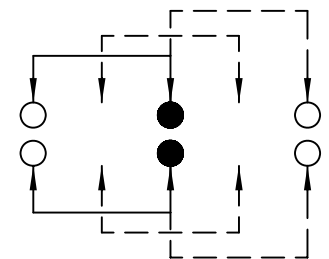

SCHEMATIC (NON-SHORTING)

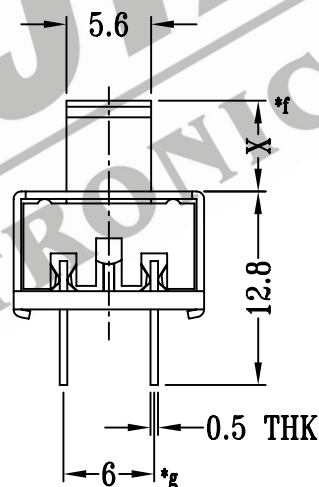
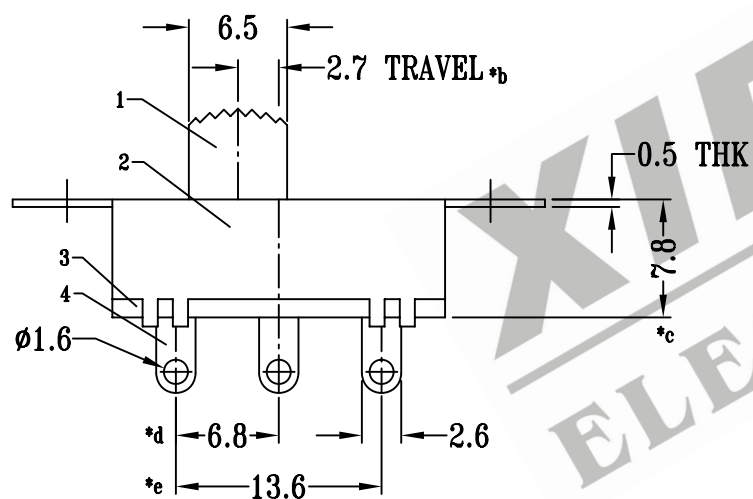
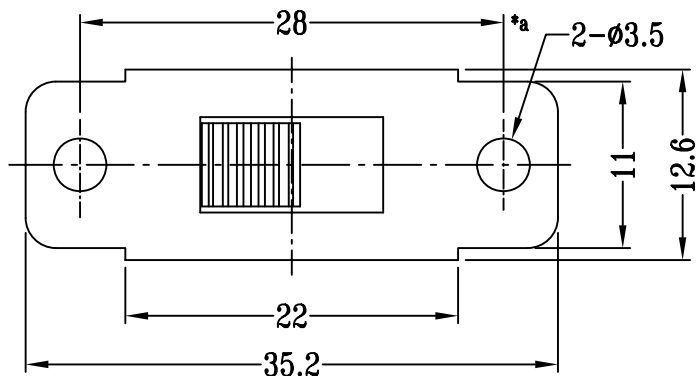
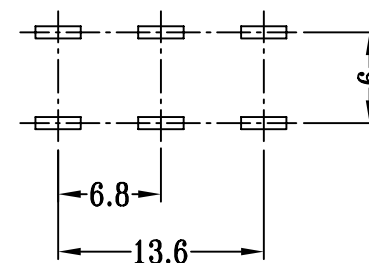

P.C.B LAYOUT

注:带"*"表示关键尺寸(7个)

8	CONTACT CLIP	PBS STRIP	2	Ag PLATED	TOLERANCE UNLESS SPECIFIED	SHENZHEN XIEJIA ELECTRONICS CO.,LTD.				
7	POSITION PLATE	STEEL STRIP	1	Ni PLATED		WITHIN : 1.5±0.1mm OVER : 1.5±0.2mm	ISSUE	DATE	DESCRIPTIONS	APPD
6	STEEL BALL	STEEL	1	NATURAL	TITLE: VERTICAL SLIDE SWITCH MODEL: SS-23E28 ALL MATERIALS MUST BE COMPLIANT TO ROHS		UNIT : M M		DRWG NO : XJ-DR-SS23E28-00	
5	SPRING	STEEL WIRE	1	TEMPER		SCALE : 2:1		DWN.	ZHOUYU	2006-5-27
4	TERMINAL	BRASS STRIP	6	Ag PLATED OVER Ni PLATED		APPD.		FANGYING		2006-5-27
3	TERMINAL BASE	PHENOLIC RESIN	1	BLACK				KANGXINAN		2006-5-27
2	FRAME	STEEL STRIP	1	Zn PLATED						
1	KNOB	PC	1	BLACK						
NO.	PART NAME	MATERIAL	QTY.	FINISHING						